

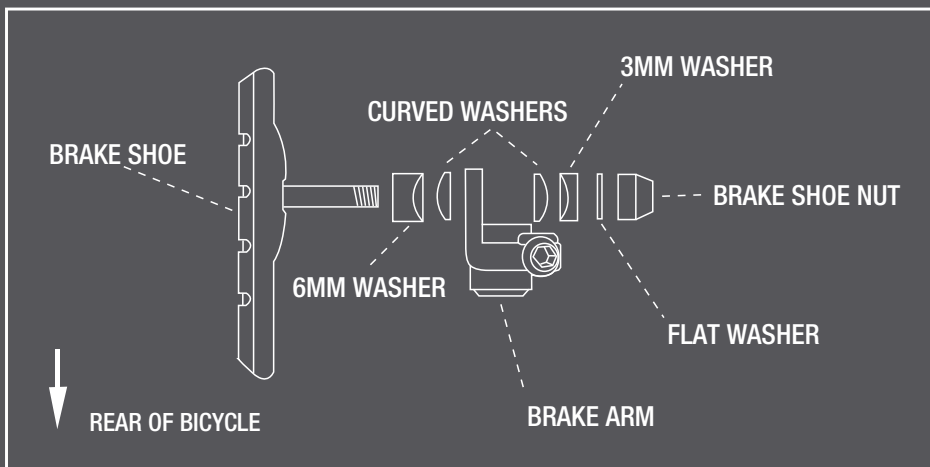

BINDER™ 450

V BRAKE PADS



INSTALLATION: 1) REMOVE OLD BRAKE PADS. 2) INSERT NEW BRAKE PADS, LONGER END FACING REAR OF BIKE. 3) USE WASHERS TO HELP POSITION THE BRAKE PAD EVEN WITH THE RIM SURFACE. 4) TIGHTEN NUT FIRMLY, BUT NOT COMPLETELY. 5) SQUEEZE BRAKE LEVER LIGHTLY TO MAKE SURE PADS REST EVENLY AGAINST RIM. 6) TIGHTEN NUT COMPLETELY WHILE HOLDING BRAKE LEVER IN A CLOSED POSITION. For warranty details go to www.thebellgarage.com



WARNING: MISALIGNED BRAKE SHOES WILL PREVENT YOUR BRAKES FROM FUNCTIONING PROPERLY. MISALIGNED BRAKE SHOES MAY ALSO RESULT IN TIRE OR RIM DAMAGE. FOR BICYCLE USE ONLY.

7015915 BINDER 450 BRAKE PADS



WWW.THEBELLGARAGE.COM

© 2012 Bell Sports, Inc. / 1-800-456-BELL
1924 County Road 3000 North / Rantoul, IL 61866 USA
Made in Taiwan

INCLUDES: ONE SET OF BRAKE PADS
AND MOUNTING HARDWARE

